

VALMATIC[®] VALVES

RESILIENT SEATED BUTTERFLY VALVE

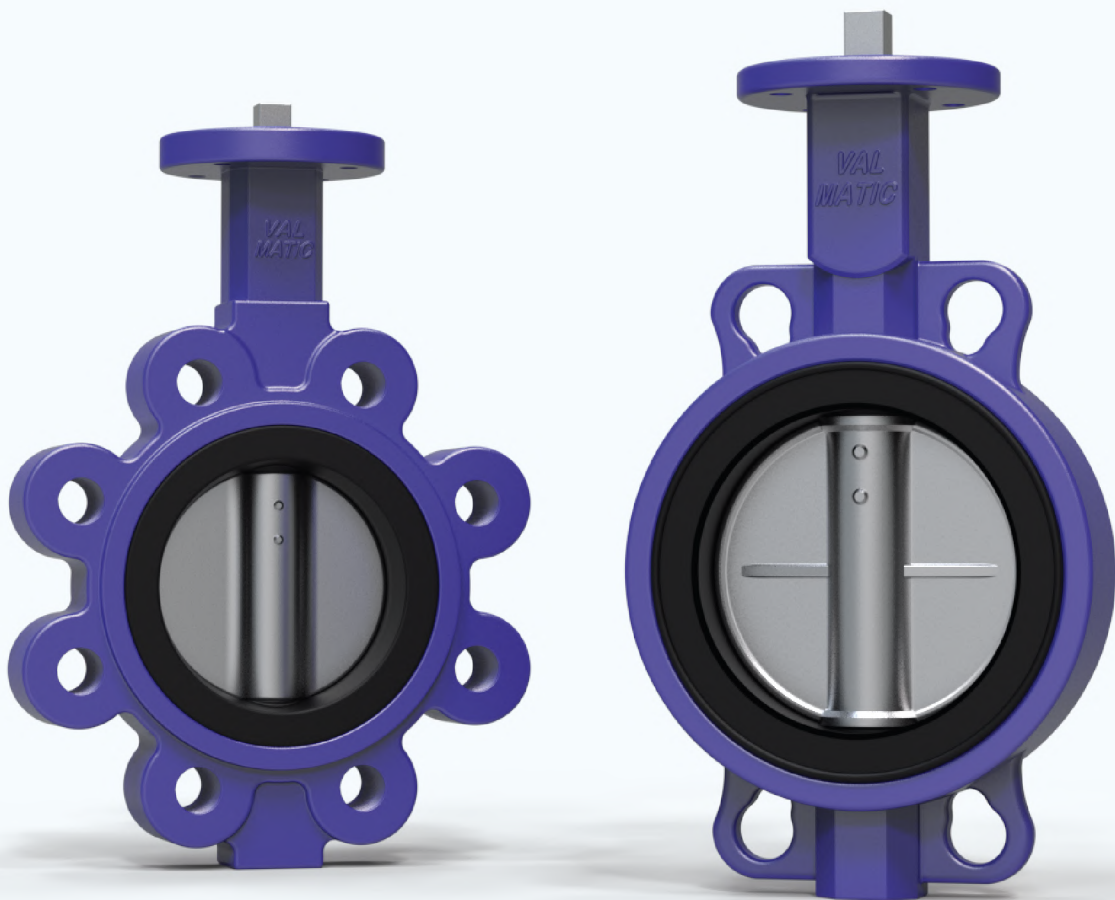

FEATURES AND BENEFITS

Valmatic Butterfly Valve Offers a Myriad of Benefits

Isolation from Line Media

Valmatic butterfly valve is designed so that the body and stem are not in contact with the line media.

Multi-functional and Convenient Seat Design

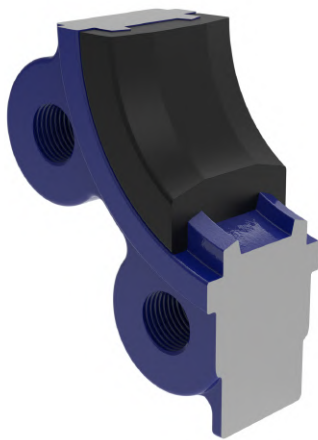

The concentric seat design ensures a tight interference fit with the valve disc. This enables a bi-directional **bubble-tight** shut off in both directions.

Cartridge style seat allows for **convenient** change without the need of special tools.

The seat extends along the valve face which provides a **tight seal** between the valve body and connecting pipe. Flange gaskets are not required.

International Standard Top Flange for Direct Mounting

Valve top flange conforms to ISO 5211 dimensions to allow for direct mounting of levers, gear operators, pneumatic and electric actuators. This keeps installation simple and minimises possible misalignments.

Concentric Design Allows for Low Pressure Drop and High Cv

The symmetric seat design ensures low pressure drop and high recovery characteristics.

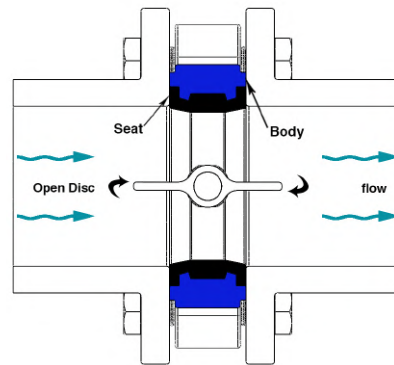

Fusion Bonded Epoxy Coating for Longer Valve Life

All Valmatic iron series butterfly valves are fusion bonded epoxy coated with a glossy blue finish.

The epoxy coating provides excellent wear resistance and protects the body from environmental attack and rust. This is especially important in outdoor applications or corrosive environments.

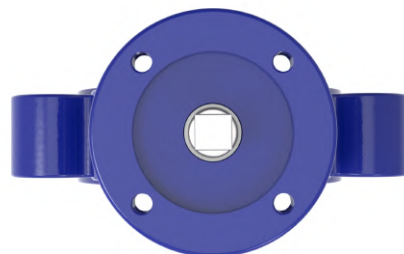

SEAT MATERIALS

4 Selections Available

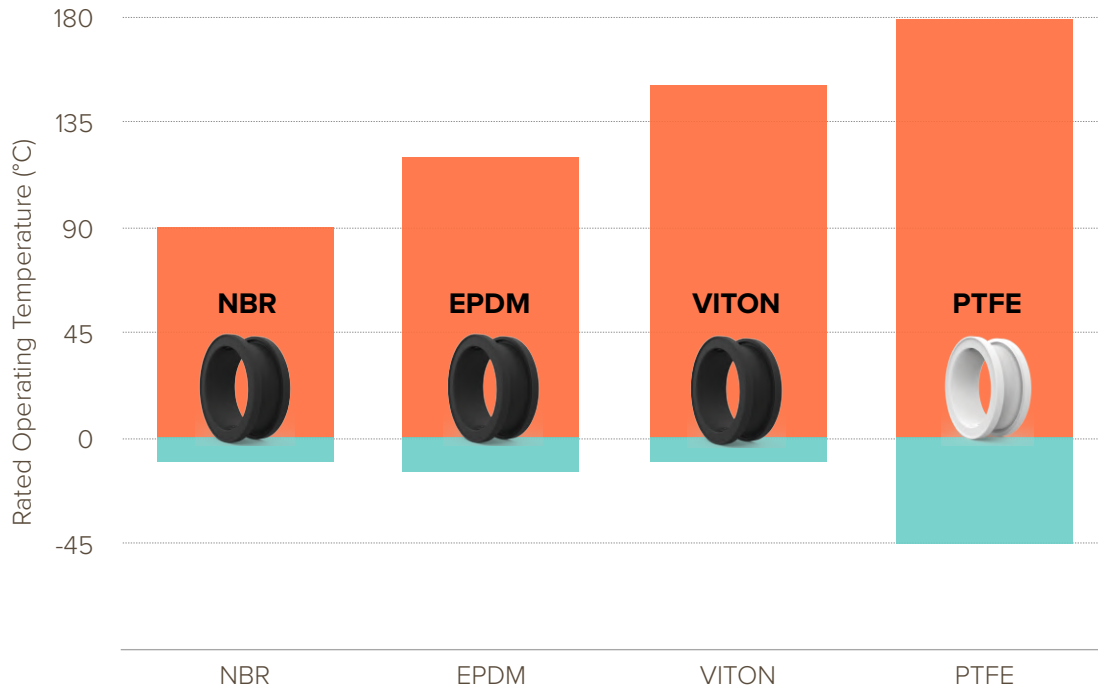

NBR (-10°C to 90°C)

NBR is also commonly known as Buna-N, Nitrile or HYCAR. It is an excellent general purpose elastomer for air, water, petroleum oils, alcohols, L-P gases and many other fluids. It exhibits good abrasion resistance and excellent resistance to compression set.

NBR is the standard Valmatic seat material.

EPDM (-15°C to 120°C)

EPDM (Ethylene Propylene Diene Monomer) is commonly used in water, phosphate, esters, ketones, alcohols, and glycols applications. EPDM is not resistant to hydrocarbon solvents and oils or any other petroleum based oils.

VITON (-10°C to 150°C)

Viton® is a synthetic rubber and fluoropolymer elastomer. It is resistant to a broad range of chemicals including hydrocarbon products and mineral acids, both dilute and concentrated solutions.

Viton® is not suitable for steam or hot water service.

PTFE (-45°C to 180°C)

PTFE (Polytetrafluoroethylene) or Teflon® is a fluoropolymer elastomer. It is the most chemically resistant of all plastics and is suitable as a seat material in steam and high temperature & pressure applications.

WAFER & LUG TYPE

Cross-sectional View

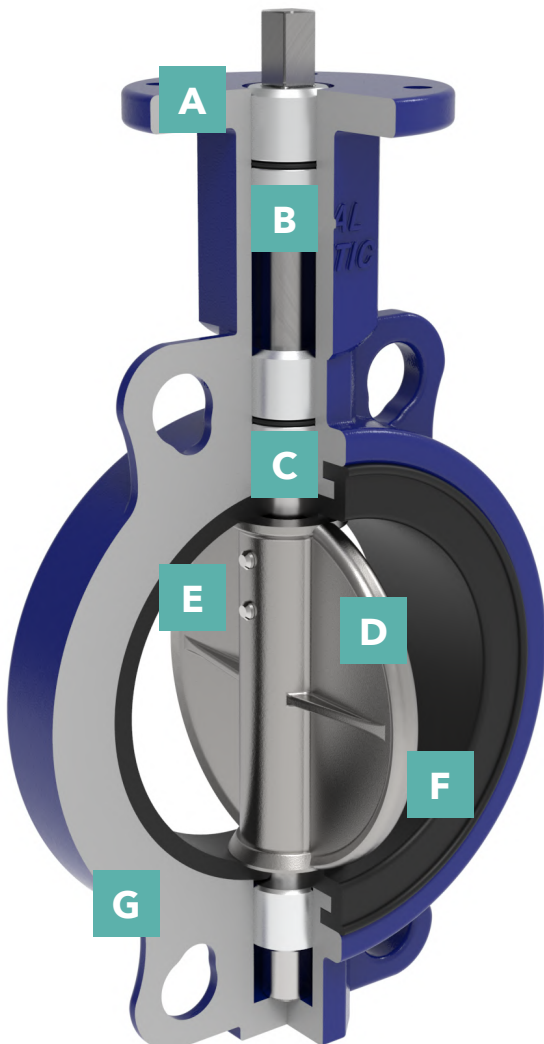

A. TOP FLANGE

ISO 5211 top flange accommodates all types of levers, gear operators, pneumatic and electric actuators.

B. BUSHING

PTFE stem bushing provides radial support for stem alignment and prevents stem deflection. The bushing isolates the stem from the valve body resulting in increased control and longer valve lifespan.

C. O-RING

The O-ring prevents line media from coming in contact with the stem or the body.

D. DISC

The disc edge is machined and polished to ensure bubble tight shut off while minimising torque and extending seat life.

E. TAPER PIN

Precision taper pins ensures a vibration proof connection between the disc and the stem. These are field replaceable.

F. SEAT

Cartridge style seat ensure convenient replaceability, a bubble tight seal in both directions and extends along the valve face so that flange gaskets are not required. They are available in different materials depending on intended application.

G. BODY

Available in wafer and lug type connections for body allows for easy assembly and maintenance. All iron series valves are coated with Fusion Bonded Epoxy Coating to ensure resistance to environmental attack and prolongs the life of the valve body.

APPLICATIONS

Economical and versatile for isolating and regulating flow

Valmatic resilient seated butterfly valve offers a light weight, economical, robust, and maintenance free solution. The concentric design of the valve and interference fit between the valve disc and seat is designed for bubble-tight directional shut-off. The variety of valve seat options accommodates a variety of process application. Lever, gear operators and pneumatic and electric actuators options are available.

COMMON APPLICATIONS

- ▶ Water and wastewater
- ▶ Air-conditioning and refrigeration
- ▶ Light slurry handling
- ▶ Pulp and paper
- ▶ Oil and gas production
- ▶ Fuel handling systems
- ▶ Marine



APPLICATION

Suitable for water, oil, gases and other non-abrasive media
(Refer to corrosion resistance table for valve materials selection)

DESIGN SPECIFICATIONS

Valmatic Butterfly valves meets the following standards/ specifications:

Valve Design & Pressure/ Temperature Ratings	BS EN 593 API 509
Actuator Mounting	ISO 5211
Face to Face Dimensions	BE EN 558-1 API 609
Testing Procedure	EN 12266-1 EN 1266-2
Wafer Connection	EN 1092-2 ASME 16.5 JIS B2220
Valve Markings	MSS-SP-67
Manufacturing Quality	ISO 9001



TECHNICAL DATA

Size Range	BS EN 593 API 5 Fig 3W (Wafer Type) DN50 - DN600 DN700 - DN1200 Fig 3L (Lug Type) DN50 - DN600 DN700 - DN1200 09
Pressure	16 bar (DN50 - DN600) 10 bar (DN700 - DN 1200)
Temperature	-10°C to 80°C (NBR) -15°C to 120°C (EPDM) -10°C to 150°C (VITON) -45°C to 180°C (PTFE)
Actuation	Lever Operated (DN50-DN200), gear operated on request Gear Operated (DN250 and above) Pneumatic or Electric Actuator

MATERIAL SELECTION OPTIONS

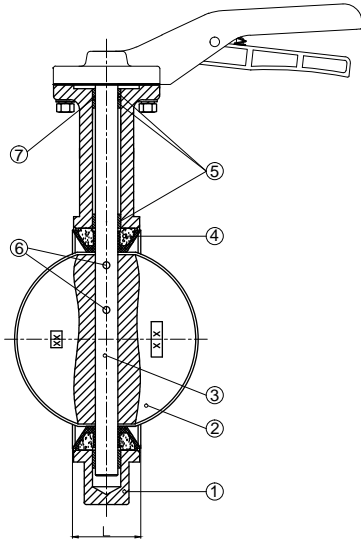

No.	Part	Material
1	Body	Ductile Iron, Carbon Steel, Stainless Steel 304, Stainless Steel 316
2	Disc	Chrome Ductile Iron, Stainless Steel 304, Stainless Steel 316, Aluminium Bronze
3	Stem	Stainless Steel 420
4	Seat	NBR, EPDM, Viton, PTFE
5	Bushing	PTFE
6	Taper Pin	Stainless Steel 304
7	O-ring	NBR

Note:

1. For other materials, please contact your local Valmatic representative.

OPERATING TORQUES (Nm)

Differential Pressure	Size (mm)													
	50	65	80	100	125	150	200	250	300	350	400	450	500	600
10 bar	13.9	15.4	21.7	37.1	57.9	93.9	173	286	429	550	755	1012	1350	2111
16 bar	15.1	17.2	23.1	39.8	61.9	102	192	323	490	625	846	1131	1500	2301

Note:

1. The torque values listed are applicable for liquids media. For dry media service, we recommend to increase the torque by 20%.
2. The safety factory is not included in the above torque data.

FLOW COEFFICIENTS (CV VALUE)

Opening Angle	Size (mm)													
	50	65	80	100	125	150	200	250	300	350	500	450	500	600
10°	0.1	0.2	0.3	0.5	0.8	2	3	4	5	6	8	11	14	22
20°	5	8	12	17	29	45	89	151	234	338	464	615	791	1222
30°	12	20	22	36	61	95	188	320	485	715	983	1302	1674	2587
40°	24	37	39	78	133	205	408	694	1072	1549	2130	2822	3658	5605
50°	45	65	70	139	237	366	727	1237	1911	2761	3797	5028	6465	9989
60°	64	98	116	230	392	605	1202	2047	3162	4568	6282	8320	10698	16528
70°	90	144	183	364	620	958	1903	3240	5005	7230	9942	13168	16931	26157
80°	125	204	275	546	930	1437	2854	4859	7507	10844	14913	19752	25396	39236
90°	135	220	302	600	1022	1579	3136	5340	8250	11917	16388	21705	39236	43116

DIMENSIONS

Fig 3W Wafer Type

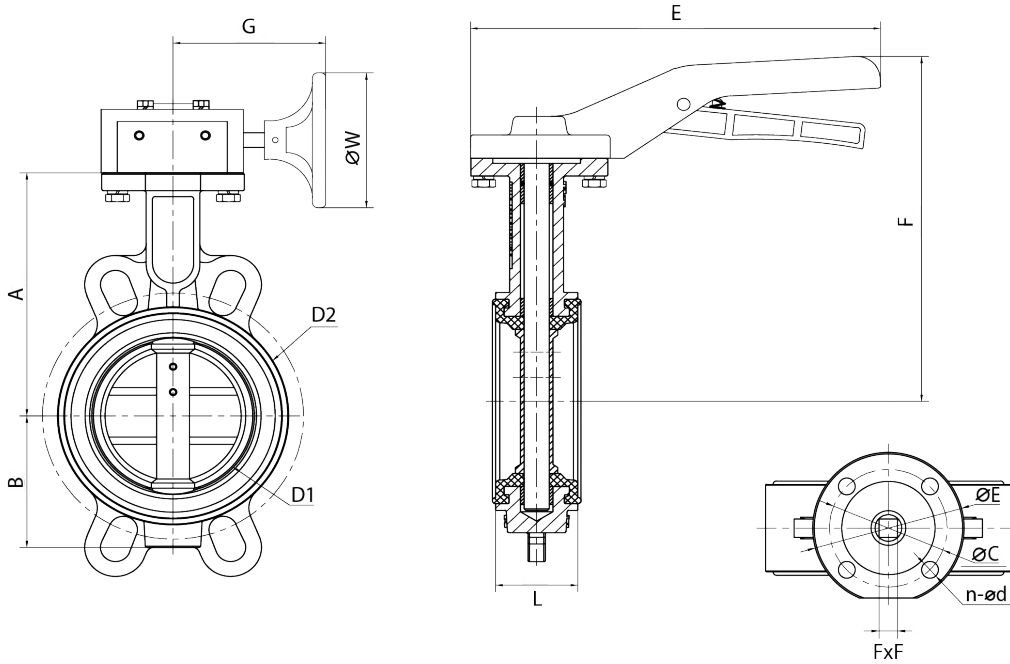

Size	L	A	B	D1	D2	E	F	G	ØW	Top Flange			FxF	
										ISO Type	ØE	ØC		n - Ød ₁
50	43	110	54	51	89	214	175	155	147	F05	65	50	4 x Ø8	9x9
65	46	136	64	63	105	214	201	155	147	F05	65	50	4 x Ø8	9x9
80	46	142	69	77	119	214	207	155	147	F05	65	50	4 x Ø8	9x9
100	52	163	85	103	146	265	233	155	147	F07	90	70	4 x Ø10	11x11
125	56	176	102	122	169	296	246	155	147	F07	90	70	4 x Ø10	14x14
150	56	190	120	154	200	296	260	155	147	F07	90	70	4 x Ø10	14x14
200	60	230	148	201	252	420	330	208	278	F10	125	102	4 x Ø12	17x17
250	68	265	188	249	306			208	278	F10	125	102	4 x Ø12	19x19
300	78	300	217	300	360			186	278	F10	125	102	4 x Ø12	22x22
350	78	340	260	331	406			186	278	F10	125	102	4 x Ø12	22x22
400	102	400	310	387	466			254	285	F14	175	140	4 x Ø18	27x27
450	114	420	330	438	522			254	285	F14	175	140	4 x Ø18	27x27
500	127	465	370	489	572			254	285	F14	175	140	4 x Ø18	36x36
600	154	530	440	590	678			301	400	F16	210	165	4 x Ø22	36x36

Note:

1. Valves DN50-200 are supplied standard with lever
Valves DN250 and above are supplied standard with gear operators
2. Dimensions for valve sizes above DN600 are available upon request

DIMENSIONS

Fig 3L Lug Type

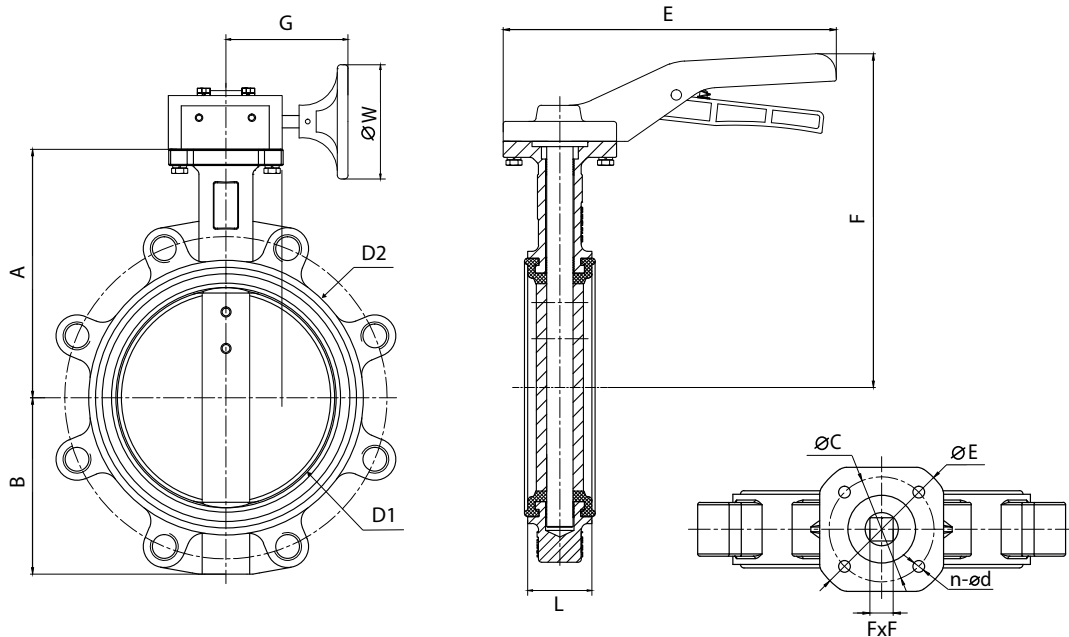

Size	L	A	B	D1	D2	E	F	G	ØW	Top Flange			FxF	
										ISO Type	ØE	ØC		n - Ød ₁
50	43	115	74	51	89	214	180	155	147	F05	65	50	4 x Ø8	9x9
65	46	132	82	63	105	214	196	155	147	F05	65	50	4 x Ø8	9x9
80	46	135	92	77	119	214	200	155	147	F05	65	50	4 x Ø8	9x9
100	52	162	108	103	146	265	234	155	147	F07	90	70	4 x Ø10	11x11
125	56	176	123	122	169	296	246	155	147	F07	90	70	4 x Ø10	14x14
150	56	190	135	154	200	296	260	155	147	F07	90	70	4 x Ø10	14x14
200	60	230	166	201	252	420	330	208	278	F10	125	102	4 x Ø12	17x17
250	68	270	200	249	306			208	278	F10	125	102	4 x Ø12	19x19
300	78	305	238	300	360			186	278	F10	125	102	4 x Ø12	22x22
350	78	340	270	331	406			186	278	F10	125	102	4 x Ø12	22x22
400	102	400	310	387	466			254	285	F14	175	140	4 x Ø18	27x27
450	114	420	330	438	522			254	285	F14	175	140	4 x Ø18	27x27
500	127	465	367	489	572			254	285	F14	175	140	4 x Ø18	36x36
600	154	536	430	590	678			301	400	F16	210	165	4 x Ø22	36x36

Note:

1. Valves DN50-200 are supplied standard with lever
Valves DN250 and above are supplied standard with gear operators
2. Dimensions for valve sizes above DN600 are available upon request

BOLTING DATA

Assembling by stud bolt

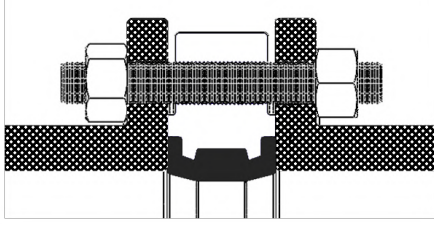

Assembling by hex bolt

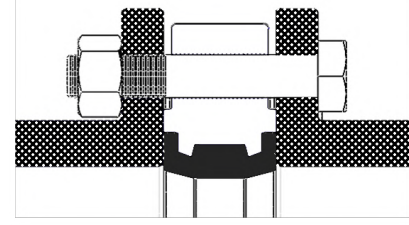

Size (mm)		EN 1092-2 PN16 Flanges		ANSI 150 Flanges	
Inch	mm	Dia. x Length	No.	Dia. x Length	No.
2	50	M16 x 130	4	5/8" x 5-1/8"	4
2 1/2	65	M16 x 130	4	5/8" x 5-1/8"	4
3	80	M16 x 140	8	5/8" x 5-1/2"	4
4	100	M16 x 150	8	5/8" x 5-1/2"	8
5	125	M16 x 150	8	3/4" x 6-3/8"	8
6	150	M20 x 160	8	3/4" x 6-3/8"	8
8	200	M20 x 170	12	3/4" x 6-1/4"	8
10	250	M20 x 180	12	7/8" x 7-1/2"	12
12	300	M20 x 190	12	7/8" x 8-3/8"	12
14	350	M20 x 190	16	1" x 8-3/4"	12
16	400	M24 x 230	16	1" x 10"	16
18	450	M24 x 230	20	1-1/8" x 11-1/8"	16
20	500	M24 x 250	20	1-1/8" x 12"	20
24	600	M24 x 300	20	1-1/4" x 13-13/16"	20

Size (mm)		EN 1092-2 PN16 Flanges		ANSI 150 Flanges	
Inch	mm	Dia. x Length	No.	Dia. x Length	No.
2	50	M16 x 100	4	5/8" x 4-1/4"	4
2 1/2	65	M16 x 100	4	5/8" x 4-3/4"	4
3	80	M16 x 100	8	5/8" x 5"	4
4	100	M16 x 100	8	5/8" x 5-1/4"	8
5	125	M16 x 120	8	3/4" x 5-1/2"	8
6	150	M20 x 120	8	3/4" x 5-1/2"	8
8	200	M20 x 130	12	3/4" x 6"	8
10	250	M20 x 150	12	7/8" x 6-1/2"	12
12	300	M20 x 160	12	7/8" x 7-1/4"	12
14	350	M20 x 170	16	1" x 8"	12
16	400	M24 x 200	16	1" x 8-3/4"	16
18	450	M24 x 210	20	1-1/8" x 9-1/2"	16
20	500	M24 x 230	20	1-1/8" x 10-1/2"	20
24	600	M24 x 260	20	1-1/4" x 12"	20

OPTIONAL OPERATORS



I-TORK ITQ Range
Electric Actuator



VALMATIC VT Range
Pneumatic Actuator
(Rack and Pinion)

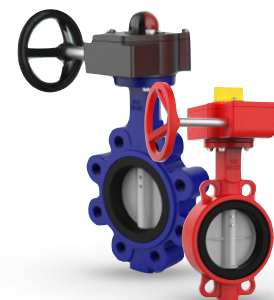

Gear Operators or
Limit Switch



INDUSTRIES WE SUPPORT

INDUSTRIAL

Palm Oil

Bulking Facilities

Chemical

Pulp & Paper

WATER

Water Treatment

Sewerage Treatment

Civil

BUILDINGS

HVAC

Plumbing

Fire Protection

ENERGY

Oil & Gas

Power Plant



OUR SALES & SERVICE LOCATIONS

HEADQUARTERS

Valmatic Engineering Sdn Bhd

10, Jalan Anggerik Mokara 31/48
Kota Kemuning, 40460 Shah Alam
Selangor, Malaysia

Tel: 603 5122 9888 / 603 5122 0099

Fax: 603 5122 3030

Email: sales@valmatic.com.my

SUBSIDIARIES

Malaysia

Valmatic M&E Engineering Sdn Bhd
Valmatic Automation Sdn Bhd
Valmatic Valves Sdn Bhd

Indonesia

PT Valmatic Indonesia
Jakarta, Medan, Pekanbaru



Your preferred brand of valves and actuators since 1997.

Discover our range of products at VALMATIC.COM.MY

All statements, technical information and recommendations in this catalogue are for general use only. Consult with Valmatic representatives for the specific requirements and material selection for your intended application. The right to change or modify product design or product without prior notice is reserved.

Valmatic® is a registered trademark of Valmatic Engineering Sdn Bhd.